

# LAMP® XL-GC01 Double Door Lock Installation Manual PAT

Thank you for purchasing the XL-GC01 Double Door Lock. In order to insure the best possible installation, we recommend that you read the following instructions closely.

**Caution** Mishandling or wrong installation of this product may lead to injury. Always clear the working area of any hazardous object before proceeding with the installation.

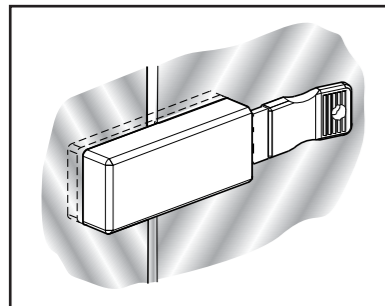

## Parts List

Before installation, please be sure to confirm all parts are contained in package.

- |                       |                            |
|-----------------------|----------------------------|
| ① ... Lock Body x1    | ⑤ ...Key x2                |
| ② ...Strike Plate x1  | ⑥ ...Clear Bumper BS-12 x1 |
| ③ ... Fixing Screw x4 | ⑦ ...Clear Bumper BS-6 x2  |
| ④ ...Gasket x2        | ⑧ ...Clear Bumper BS-2 x2  |
|                       | ⑨ ...Clear Bumper BS-32 x2 |

## Glass Processing

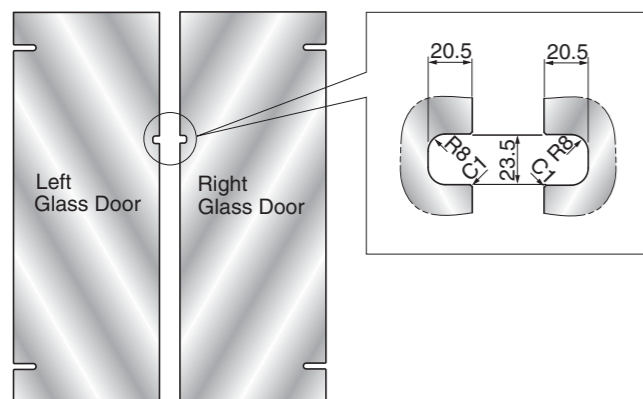

## Lock Installation Position

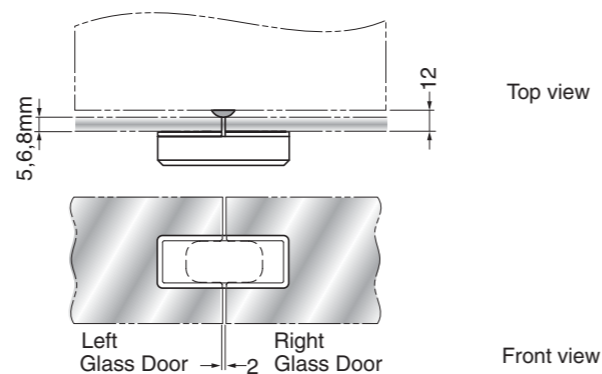

**Caution**

- Maximum door size is W500 mm x H1200 mm.<sup>(1)</sup>
- Maximum door weight is 12kg.<sup>(1)</sup>
- Applicable glass thickness is 5,6 or 8mm.
- Should you have any question with regards to the glass cut out, please contact your local glass supplier.

<sup>(1)</sup> Only applies when using in combination with XL-GC07 hinge.

## 1 Lock Body Assembly

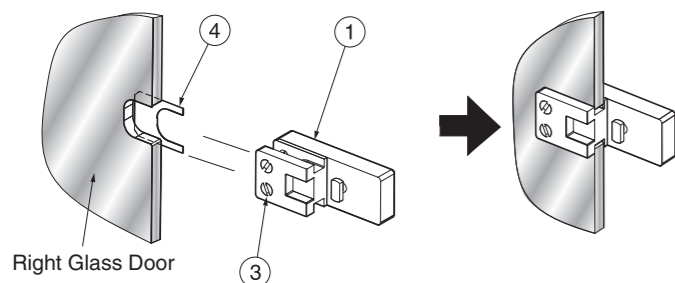

Inside view

Insert the gasket ④ in the lock body ① so that it will be located on the outer side of the cabinet. Then fit the lock body on the glass door and fasten fixing screws ③.

## 2 Strike Plate Assembly

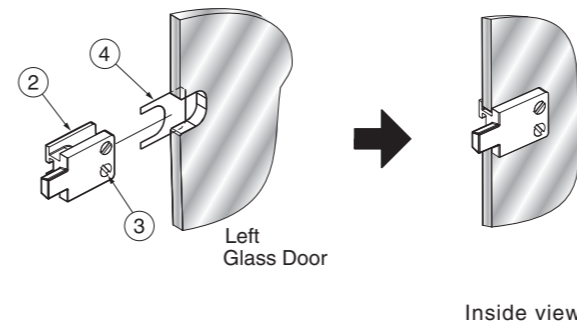

Inside view

Insert the gasket ④ in the strike plate ② so that it will be located on the outer side of the cabinet. Then, fit the strike plate on the glass door and fasten fixing screws ③.

## 4 Key Operation

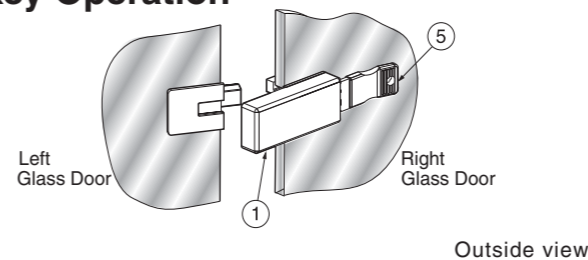

Outside view

Make sure to insert key ⑤ into the slot of the lock body ①, before closing the doors for the lock adjustment.

### Caution

Always insert the key ⑤ into the slot of the body lock ① before closing the door. Failure to do so may result in damage to the lock.

## 6 Bumpers

Top and Bottom Panel	Door Thickness	Bumpers (T)
5~8	5 mm	⑦ BS-6 (6.2)
	6 mm	⑧ BS-2 (5)
	8 mm	⑨ BS-32 (3.1)

Affix clear bumper ⑦, ⑧ or ⑨ to the top and bottom of both doors, where the glass makes contact with the cabinet body. The clear bumper size should be selected according to the glass thickness as shown in the table above.

## 3 Locking Operation

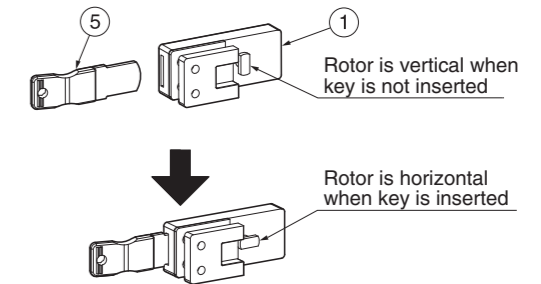

Insert key ⑤ in the slot of the lock body ① as shown above in order to unlock. Simply remove the key ⑤ in order to lock. We recommend that you test the good operation of the rotor before proceeding to the final adjustments.

## 5 Lock Alignment

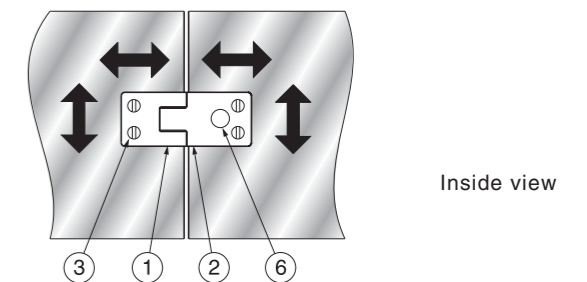

Inside view

To ensure a smooth operation of the lock, align lock body ① and strike plate ② both vertically and horizontally by loosening the fixing screws ③ on the back side. Adjustment range is 2 mm vertically and 1mm horizontally. Affix clear bumper BS-12 ⑥ on the rear of strike plate ② as shown above in order to prevent scratches to the body surface when the right door is closed before the left one.

## 7 Door Alignment

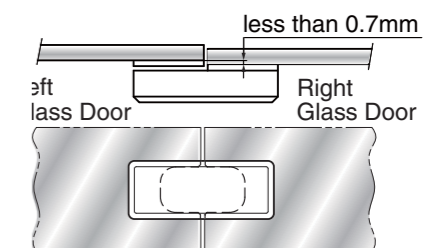

For smooth operation, we recommend to make sure of the doors parallelism. Moreover both doors depth alignment should be maintained within 0.7mm as shown above.

**SUGATSUNE KOGYO CO.,LTD.**  
 Phone: +81 3 3866 2260  
 Fax: +81 3 3866 4447  
 E-mail: export@sugatsune.co.jp  
 Website: www.sugatsune-intl.com

**SUGATSUNE KOGYO (UK) LTD.**  
 Phone: +44 118 9272 955  
 Fax: +44 118 9272 871  
 E-mail: sales@sugatsune.co.uk  
 Website: www.sugatsune.co.uk

**SUGATSUNE AMERICA, INC.**  
 Phone: +1 310 329 6373  
 Fax: +1 310 329 0819  
 E-mail: sales@sugatsune.com  
 Website: www.sugatsune.com

**SUGATSUNE SHANGHAI CO., LTD.**  
 Phone: +86 21 3632 1858  
 Fax: +86 21 3632 1868  
 E-mail: lamp@sugatsune.com.cn  
 Website: www.sugatsune.com.cn

ISO9001(Japan Offices and Sugatsune America) and ISO14001(Chiba Production division and Logistic center), certified.